

VENCO BATHWARE INSTALLATION AND MAINTENANCE INSTRUCTIONS

ONE PIECE & SECTIONAL SHOWER STALL & TUB INSTALLATION:

1. Frame pocket as shown on framing details.
2. Allow 1/4" clearance to facilitate leveling and shimming.
3. For sectional unit disassemble walls and base. Save fasteners for reassembly.
4. Install strainer and overflow or shower stall strainer.
5. Move all components into bathroom.
6. For sectional unit place gasket (supplied) on base flange (in front of bolt holes, see sketch) and reassemble with bolts supplied. **DO NOT** assemble without gaskets or the unit will leak.
7. Optional roof cap should be installed now. (See instruction below)
8. Locate and drill all holes for faucet(s), spout and showerhead.
9. Level and plumb unit, shimming as necessary. Shim under the unit base to prevent flexing when unit is used.
10. Make double sure walls are plumb and base is level or doors will not fit properly. Ill fitting doors are prone to leaking. Breakage of the glass panels may occur if the panels are twisted and stressed.
11. Drill pilot screw holes in flange.
12. Fasten unit to studding with countersunk flat head drywall screws taking care not to twist or buckle the fibreglass flanges or damage will result to the gelcoat finish.
13. Caulk all joints with bathtub caulking.
14. Finish the wall with wall materials of your choice.

OPTIONAL ROOF CAP INSTALLATION:

1. Locate the top on unit if additional trimming is necessary use a file or grinding wheel to shape to size.
2. The face apron can be trimmed with a jigsaw to suit application.
3. Drill required mounting holes through roof cap top flange and mating unit flange.
4. Fasten roof cap to unit with drywall screws.
5. Continue with the unit installation.

CLEANING INSTRUCTIONS:

1. Clean with warm water and liquid detergent. Do **NOT** use abrasive cleaners or scouring pads as this will marr the gelcoat finish.
2. To maintain a lustre occasionally apply a coating of liquid wax after cleaning. Buff to a gloss finish.

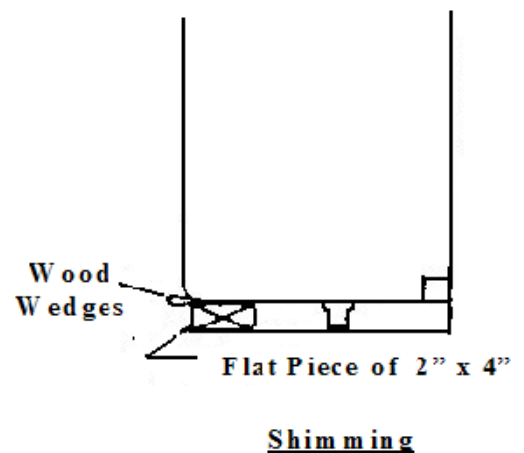
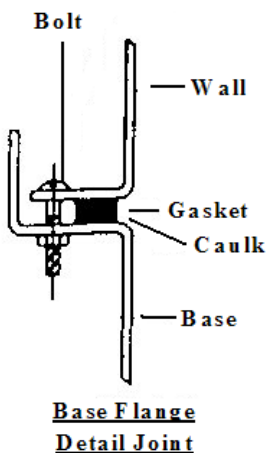

20 BURNETT AVENUE
WINNIPEG, MANITOBA R2G 1C1
TELEPHONE: (204) 668-9320 / FAX: (204) 663-9115

